



IMPORTANT: READ FIRST



FOAM SEAL INSTALL TO HEADER RAIL ENDS

TOOLS NEEDED:
T-30 Torx driver, 3/8" drive
short extension, ratchet

1. Remove factory cab header rail
2. Use T-30 Torx driver to remove 5 fasteners securing header rail to front bulkhead below cab rear window
3. Peel backing paper off of foam seal and adhere to header rail endcaps
4. Reposition factory cab header rail on truck bed
5. Install and torque all mounting bolts to 7.5Nm (66.5 lbs-in)

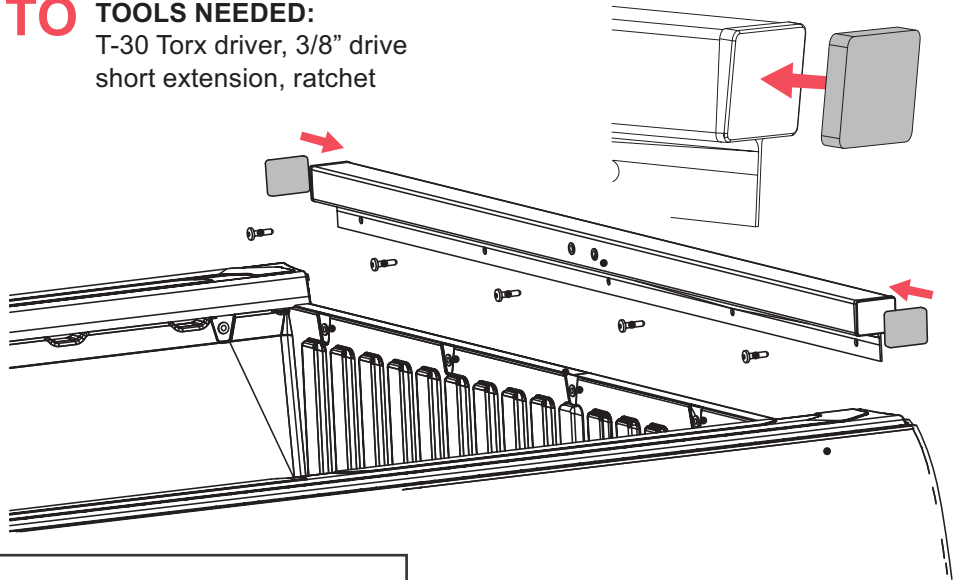

Parts included:

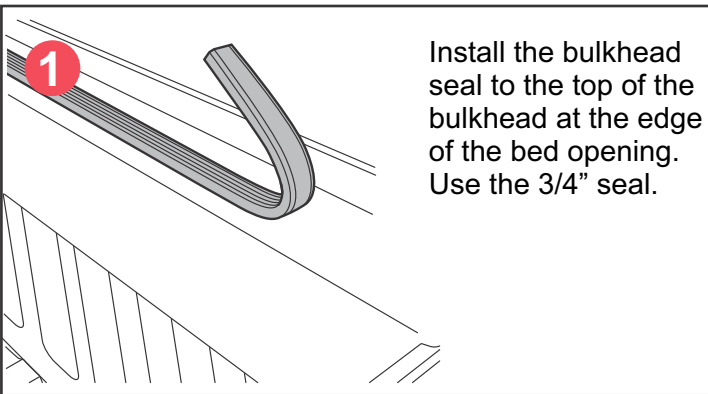
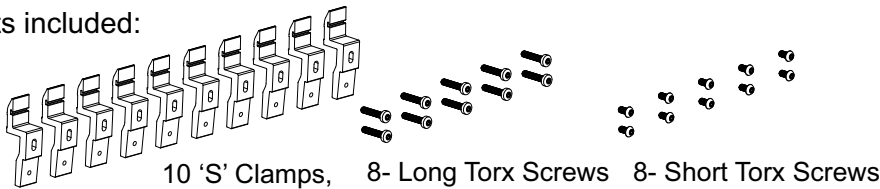

2 Remove the factory installed accessory track system, set aside for reinstallation.

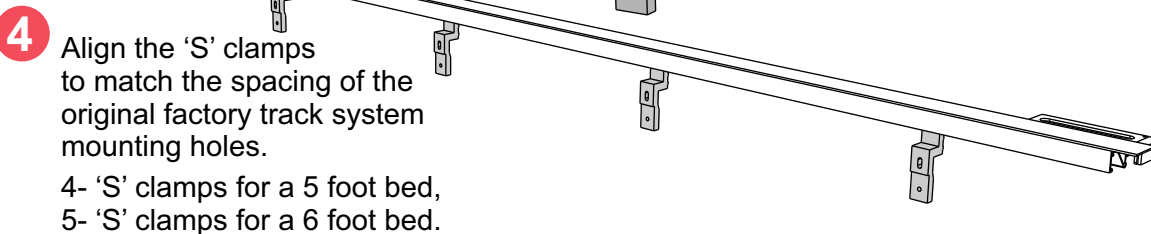
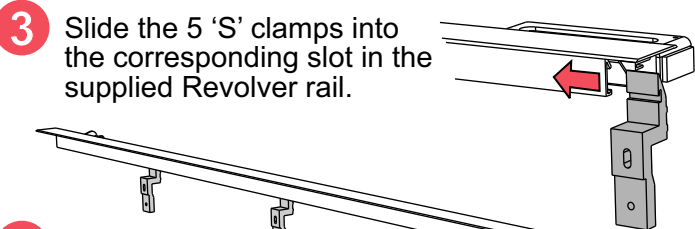
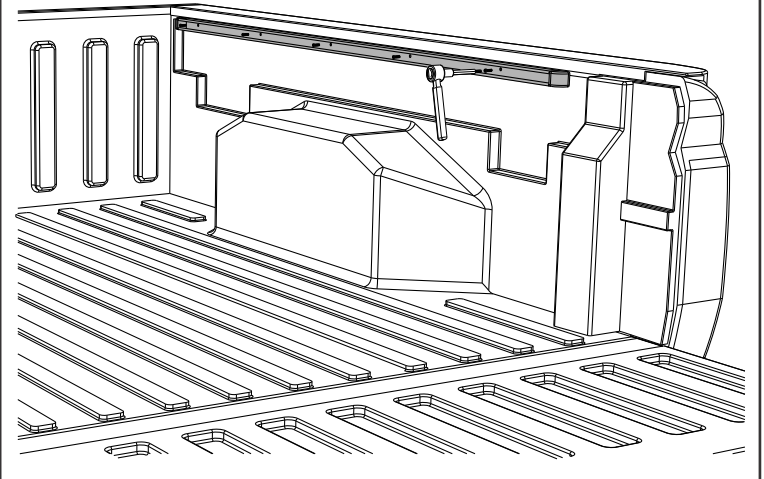

- 5** Mount the supplied Revolver rail into the original factory mounting holes using the supplied long Torx screws through the middle slot of the 'S' clamps.

Align the rail with the front/cab bulkhead, per Step 5A, tighten the screws.

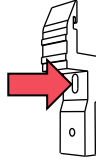

5A

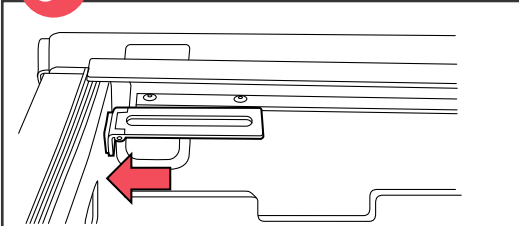

Position the rail with the silver, slotted bracket all the forward, towards the cab, the front of the vehicle.

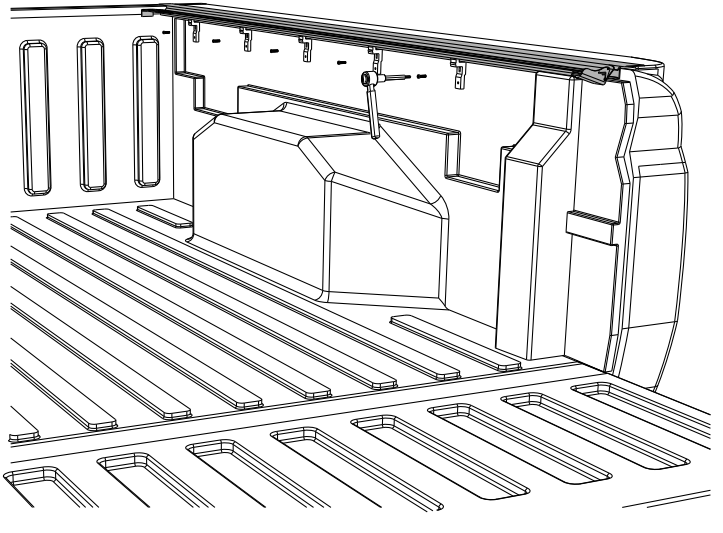

- 6** Remount the factory track system using the supplied short Torx screws into the threaded holes at the bottom of the 'S' clamps.

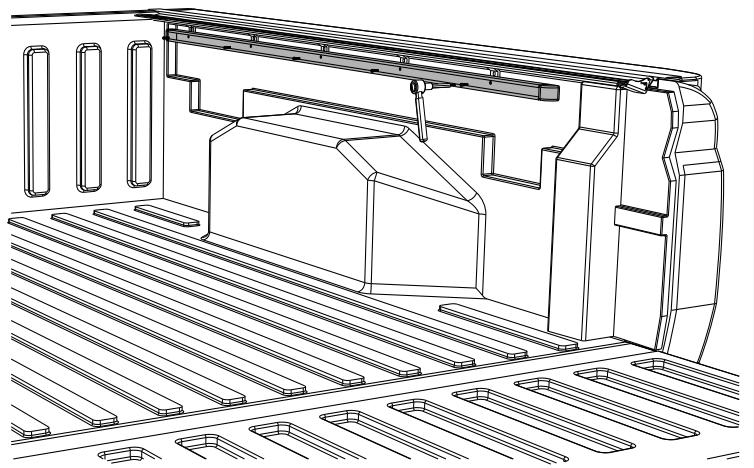
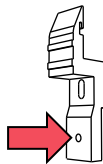

- 7** Remove the end cap from the factory accessory track system. Then slide the buckle strap bracket into the rail. Replace the end cap.

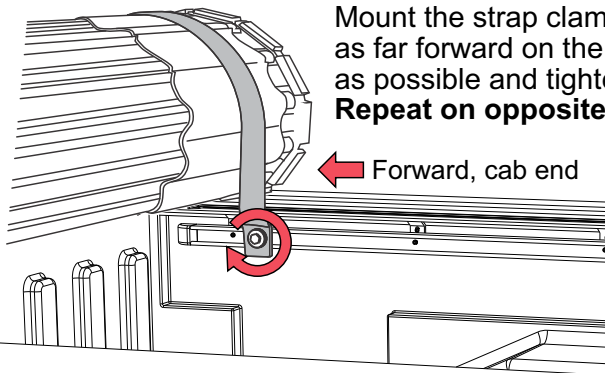

Mount the strap clamp as far forward on the rail as possible and tighten. **Repeat on opposite side.**

← Forward, cab end

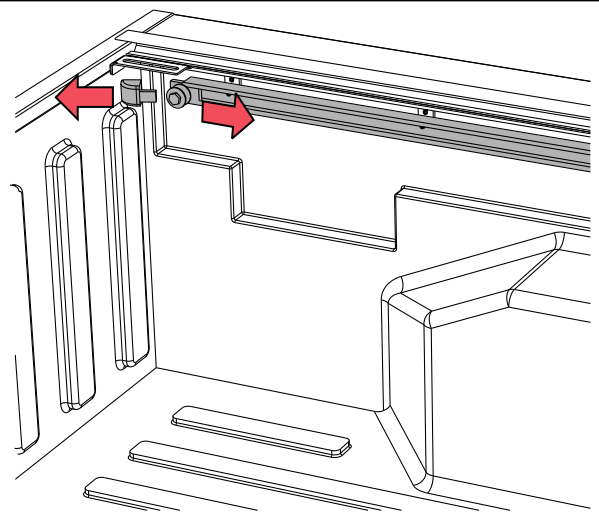

Return to standard Installation Sheet, Step 8.